

# Micro Vacuum Pump for Analysis



## Application- based technology

- Pre-destined for integration into analytical and medical instruments
- Optimized flow properties
- Compact and powerful; vacuum up to 500 mbar absolute; flow rate up to 1.8 l/min (at atm. pressure)
- No contamination, maintenance-free

# Micro Diaphragm Vacuum Pump NMS 020 L

This micro pump is specially designed for pumping gases. It enables reliable processes in analytical instruments. Of course it is also ideally suited for medical applications like blood-pressure measurement instruments.

The pump heads are made of plastic and therefore able to resist corrosion.

Important characteristics:

- high gas-tightness
- maintenance-free in operation
- no contamination in pump area
- corrosion resistant

## Dimensions in mm

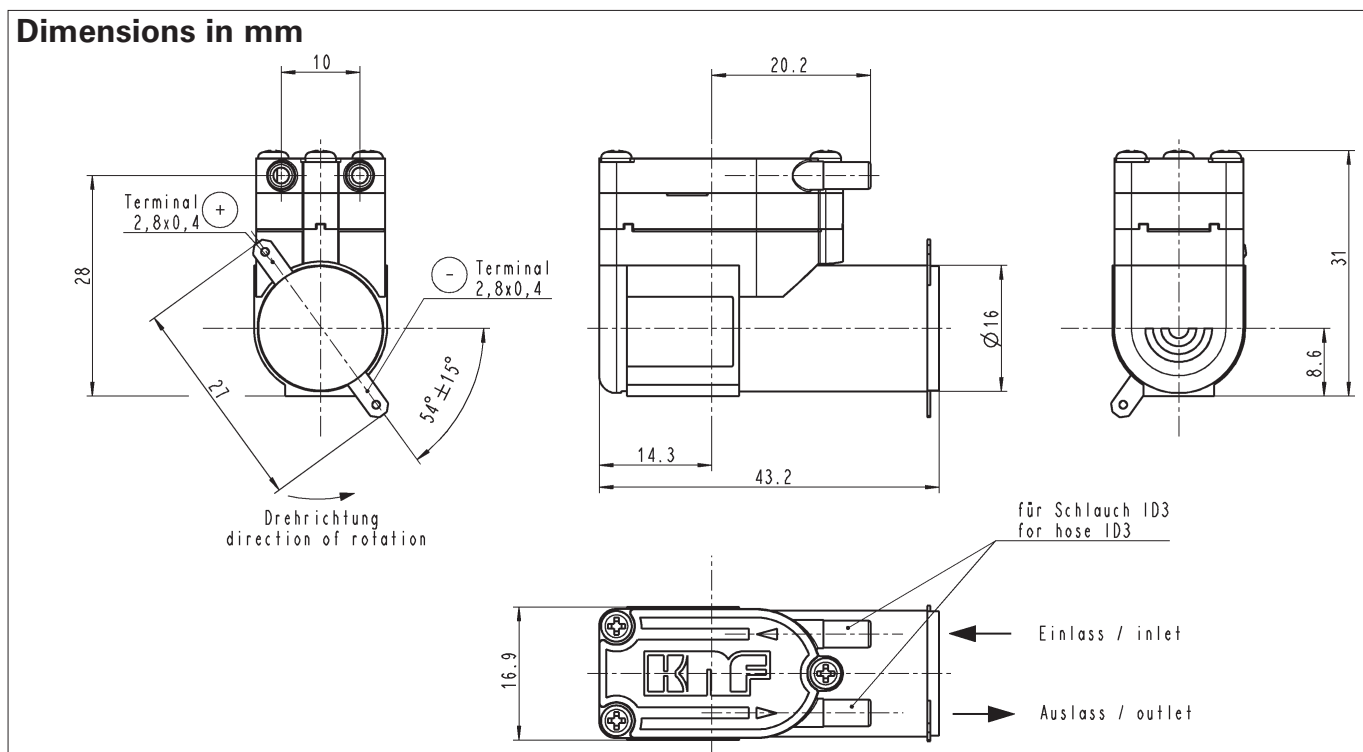

## Performance characteristics

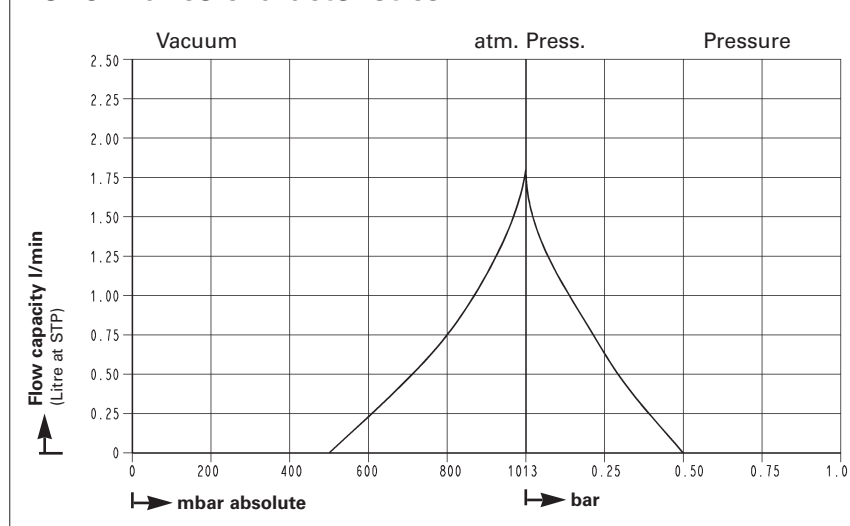

## Technical data

Delivery *:	1,8 l/min*
Ultimate vacuum:	500 mbar abs.
Pressure	0,5 bar

\*) at atm. Pressure

Voltage:	6 V DC
Weight:	32 g

**KNF Neuberger GmbH Germany, Membranpumpen + Systeme**

Alter Weg 3, D-79112 Freiburg, Tel. +49(0)7664/5909-0, Fax +49(0)7664/5909-99, www.knf.com, E-mail: info@knf.de